

ACSmith®

proplanet  
Series

Baby - Safe.\*  
Earth - Safe.

ACSmith®  
Innovation has a name.

Call 1800 103 2468 / 1860 500 2468 for a free demo\* today  
or visit [www.aosmithindia.com](http://www.aosmithindia.com)



Plot No. 300, Phase - II, KIADB Industrial Area, Harohalli, Kanakapura Taluk,  
Ramanagara District, Karnataka - 562 112, India. CIN: U31909KA2006PTC040282  
f <https://www.facebook.com/aosmithin> | t <https://twitter.com/AOSmithin>

\*Available only in selected cities.

AOS/PP\_R0/01/21



# Say hello to A. O. Smith.

Founded in 1874 by Charles Jeremiah Smith, the A. O. Smith Corporation began as an engineering company in Milwaukee, Wisconsin. Today, we are the world's No.1 manufacturer of water heaters. This drives our pursuit for excellence when it comes to water purifiers as well. For the past 145 years, our singular purpose has been to create stellar products that deliver the best performance with the best technology. And to this day, we live strongly by that belief.



## Over a century of innovation.

A. O. Smith enjoys a rich history of achievements. A glimpse at our 144-year history reveals numerous engineering and technical achievements.



**1874**

The Smith family started a small mechanical shop in Milwaukee, North America.



**1906**

A. O. Smith was North America's largest automobile frame manufacturer.



**1936**

A. O. Smith patents the glass-lined water heater.



**1995**

Reach into the Asian market by entering two joint-ventures in China.

**1889**

The company enters the bicycle industry.



**1927**

A. O. Smith was a leading supplier of line pipe.



**1954**

The water heater division introduces the first glass-lined commercial water heater, the A. O. Smith Burkay® B-65.



**2010**

State-of-the-art plant set-up in Harohalli, Bengaluru in 2010.



# Baby - Safe.\* Earth - Safe.



## What a purifier.

Our range of water purifiers offer everything you've thought of. And more. Engineered with the finest technologies, our water purifiers are intuitive, efficient and beautiful. Whether it's the top-of-the-line A. O. Smith Green RO series or the invisible X5+, you'll find one that best suits your needs.

## Why Baby-Safe\* & Earth-Safe?

**Baby-Safe\*:** ProPlanet series is equipped with RO + Silver Charged Membrane Technology (SCMT) which gives you 100% RO purified, baby-safe\* water, by using an 8 stage purification process.

**Earth-safe:** With its Advance Recovery Technology, ProPlanet ensures that you save 9000L of water annually, which is potentially sufficient to fulfill drinking water requirement of 2 families of 4. Hence, it is India's first 5 star rated water purifier in terms of water saving, making it earth-safe.

## 100% RO, Zero Compromise.

In ordinary purifiers, the water bypasses the RO membrane, increasing the risk of contamination. Our purifiers pass 100% of the water through our patented side stream RO membrane. All of which is further purified with our Silver Charge Membrane Technology (SCMT). Additionally, Min-Tech re-introduces essential minerals like Calcium and Magnesium that would otherwise have been lost. Giving you water that's clean and tasty.

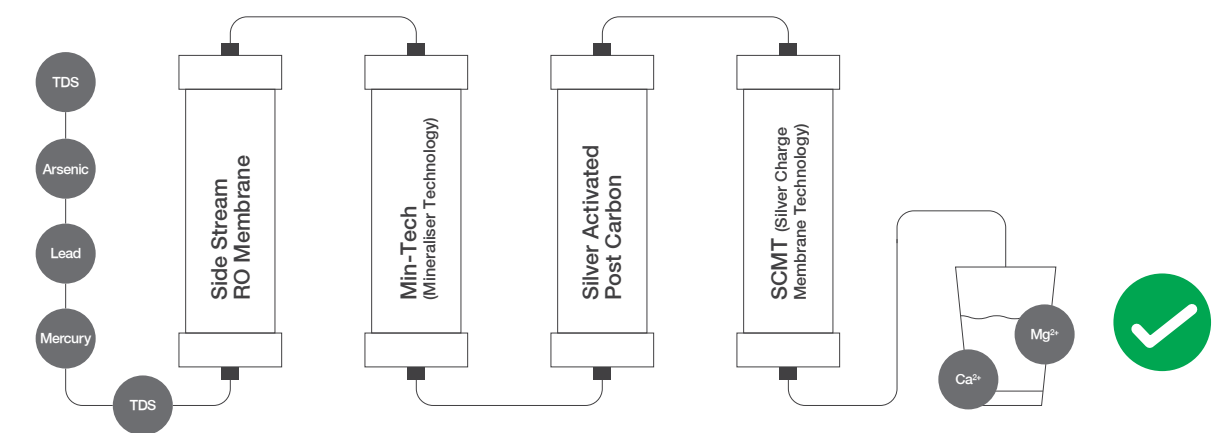

(ZX Double Protection Dual filter: Silver Activated Post Carbon + SCMT)

## A. O. Smith vs Ordinary RO + UV

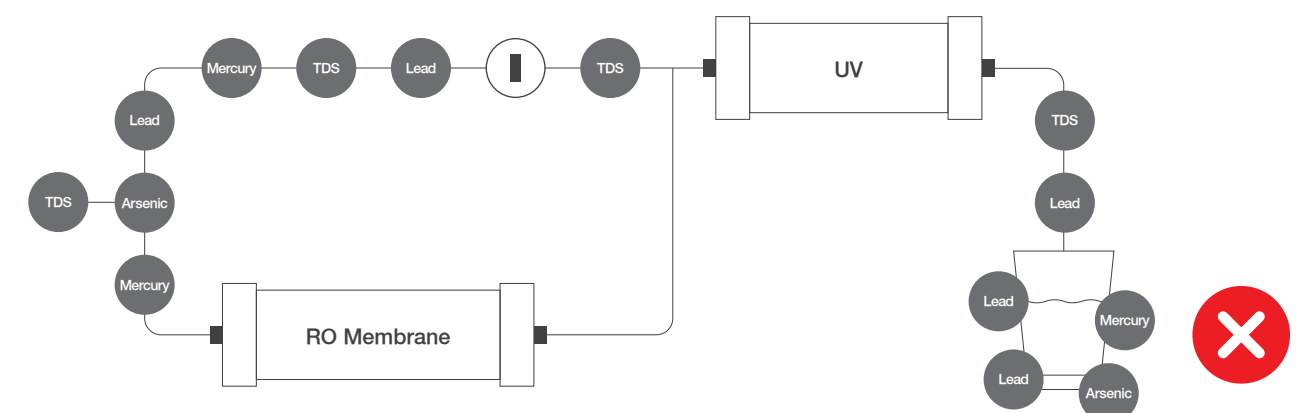

Water bypassing the RO membrane can contain harmful substances like TDS, lead, arsenic, fluoride, pesticides and other chemicals.



## 8-stage 100% RO+SCMT.

Our 8 stage RO purification system, in ProPlanet undoes what the world has done to water. At the touch of a button, you get water the way it was meant to be. Fresh, clean and so good that even safe for babies\*.

### 1 Pre-Filter

The first step in our filtration process is the advanced Pre-Filter. It removes sediment and other particulate matter.

### 2 Sediment Filter

The Sediment Filter removes finer sediment and particulate matter. This increases the life of the RO membrane and subsequent filters, resulting in low maintenance costs.

### 3 Pre-Carbon Filter

The Pre-Carbon Filter removes any unpleasant colour, taste and odour, including chlorine. It ensures that your water is healthy and tastes the way it was meant to.

### 4 ART™ MAX (Advance Recovery Technology™)

Unlike other purifiers, our breakthrough Advance Recovery Technology™ recovers 2X more water\* when it runs through the purifier, ensuring minimal water wastage. It's good for the environment and good for you.

### 5 Patented Side Stream Membrane

Our patented side stream RO membrane removes bacteria, viruses, cysts, heavy metals like lead, mercury and arsenic, as well as pesticides and fluorides. The system is designed to ensure 100% of the water passes through the RO membrane and none of it bypasses it so no impurity stands a chance of passing through.

### 6 Min-Tech (Mineraliser Technology)

Min-Tech adds essential minerals like Calcium and Magnesium back into the water. So the water you get, tastes fresh and natural with a balanced pH level.

### 7 Silver Activated Post Carbon

The Silver Activated Post Carbon filter is our 7<sup>th</sup> stage of purification. Ionized silver is a powerful antimicrobial agent. So your water runs through a silver-based filter that prevents any microbial growth. Because impurity should have no place in your drinking water.

### 8 SCMT (Silver Charge Membrane Technology)

SCMT prevents any potential secondary microbial contamination post RO purification.

Filtration Technology	SCMT	UF	MF	UV
Virus	✓	✗	✗	✓
Bacteria	✓	✓	✓	✓
Cysts	✓	✓	✓	✓
Particulates	✓	✓	✓	✗
Endotoxins	✓	✓	✓	✗
Colloids	✓	✓	✗	✗
Chemical reduction	✓	✗	✗	✗
Phosphates	✓	✗	✗	✗

\*Under standard test condition. ART™ patent applied.  
Disclaimer : Product images / color shown may vary from actual model.

# proplanet

## Baby - Safe.\* Earth - Safe.



ProPlanet series is designed for the discerning consumer-both environment conscious and health conscious.

The stylishly crafted ProPlanet water purifiers are equipped with RO + Silver Charged Membrane Technology (SCMT) that gives you 100% RO purified, baby-safe\* water, using an 8 stage purification process. The elegant and stylish design of ProPlanet enhances the beauty of your kitchen and also saves 2X more water than an ordinary RO water purifier\* making it earth-safe too.

### Benefits



**Baby-Safe\* water** with 8 stage purification and double protection of 100% RO+SCMT



**All Time Fresh water** with in-tank UV purification



**Retains natural taste with essential minerals** using Alkaline MIN-TECH



**Elevate your kitchen décor** with sleek, compact and contemporary design



**Give back to your planet, save 9000L\*\* of water** annually through ProPlanet's ART™MAX



**Feel proud about your contribution** through Smart Intelli-Display panel

### ProPlanet Smart Intelli-display

The Intelli-Display indicator has a Pro-health indicator, a Green Leaf indicator and a Go Green Indicator.

The bar between Pro-health and Green Leaf indicator shows the consumption of baby-safe\* water.

The Green Leaf indicator in the center glows after completion of each cycle (~ 10 L) of water saving. This saving helps you get an idea about the amount of water saved and hence your contribution towards the planet.

Each bar between Go Green and Green Leaf indicator shows the saving of more than 3L of water.\*\*





With its smart compact design, contemporary looks and cutting-edge features, ProPlanet water purifier goes well with any tastefully-done kitchen interior. This meticulously crafted new-age water purifier helps you save water and do your bit towards a greener environment.



## ATF Technology (All Time Fresh)

UV LED in tank ensures  
purified water is fresh all time(24x7)

24x7 

## Night Assist

The beautiful night assist light helps you  
locate your water purifier at night and  
elevates the look of your kitchen.

# Water warriors.

The ProPlanet series is exclusively crafted for discerning consumers, who not only seek the best water purification product proposition but also are environment conscious at the core. ProPlanet series is India's 1st 5 star rated water purifier in terms of water savings (Certified by IAPMO)

A. O. Smith ProPlanet series is a range that gives you healthy water in an eco-friendly way.

Ordinary RO water purifiers use four glasses of water to make just one glass of clean water. But A. O. Smith water purifiers with Advance Recovery Technology™ (ART™) save 2X more water\*. With high water recovery of 60% in ProPlanet series, you save more than 9000L of water annually\*, which is potentially enough for 2 families of 4. Unlike ordinary RO purifiers, the water doesn't bypass the RO membrane. Instead, we pass 100% of the water through it. What this means is that all the water is purified with minimal wastage.





# proplanet

*Series*



ProPlanet series has a water recovery of more than 60%. It is India's 1st and only 5 star rated water purifier in terms of water savings certified by IAPMO (International Association of Plumbing and Mechanical Officials) ProPlanet series water purifiers are compliant to 'IAPMO - I WPSC-01:2019 Evaluation of Point of Use Water Purification System.

## Instant hotness.

A good-looking machine that dispenses mineralised hot water in an instant. Whether it's for a quick cuppa or instant noodles, you can choose between water at 45°C for drinking or 80°C for cooking. No more waiting for water to bubble over a flame. Simply press a button and it's right there.







## Let there be light.

### Night Assist.

Our ProPlanet P7 and P6 purifiers come with Night Assist. It helps you locate your purifier in the dark without having to switch on the lights.

## Support. After sales.

Every A. O. Smith water purifier comes with A. O. Smith's Power of One service#. Simply call our 24x7 helpline and we'll take it forward from there.



### 1 Hour Response

We will schedule a service appointment within one hour of your call to our customer care number.



### 1 Day Resolution

A company authorised service technician will visit within 24 hours of your call.



### 1 Time Fix

Our company authorised service technician will carry and replace any non-working component on the very first visit.



### 1-Year Warranty

All our ProPlanet series water purifiers come with a 1-year comprehensive warranty\* that includes the filter and the patented side stream RO membrane. To give you complete peace of mind.



#For calls registered at A. O. Smith Call Centre before 4 pm only. Available only in selected cities.  
\*Inclusive of all filters and RO membrane.  
Disclaimer : Product images / color shown may vary from actual model.

# Features you'll love.

## Stands up. Stands out.

Every A. O. Smith water purifier is conveniently designed to either be placed upright on a table or mounted on a wall. Because a true masterpiece will look good anywhere.



### Child-Lock Button.

The Child-Lock feature prevents your kids from accidentally starting the flow of hot water and possibly scalding themselves.



### Advance Alert.

The Advance Alert is a handy system that lets you know if the RO membrane or other filters need changing.



### Auto Flush.

The Auto Flush notifies you about the purifier flushing out any impurities present within. Consider it detox.



### Shows it all.

The display on your A. O. Smith RO water purifier provides useful information like water temperature, tank full, filter alerts and power mode in one beautiful digital package.



### Drip tray.

The drip tray in your A. O. Smith RO water purifier is super convenient when you want a glass of water and have your hands full. But it's also easy to remove when filling large bottles or vessels.



### Healthy water. Maximum capacity.

Every one of our purifiers comes with water storage capacity of up to ten litres. So you'll never run out of clean and healthy water.

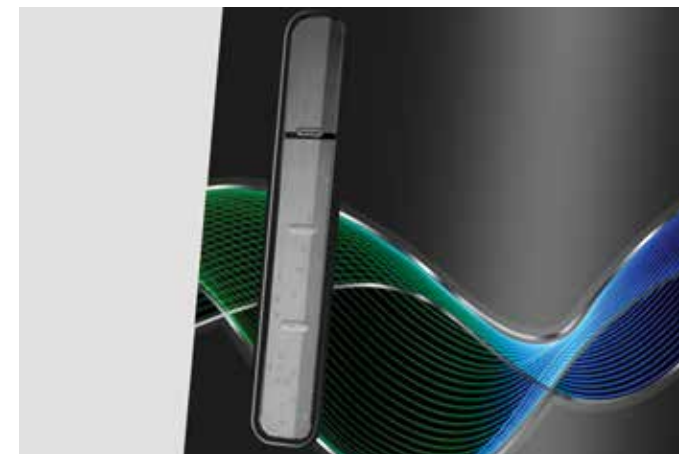

### Water level indicator.







The translucent level indicators show you how much water there is. So you don't have to guess.



### Food-grade water tank.

Your A. O. Smith RO water purifier is made from virgin food-grade ABS. This ensures no leaching of toxins from the water tank into the water. It keeps your water clean and healthy.

Disclaimer : Product images / color shown may vary from actual model. Design, feature and specifications mentioned are subject to change without notice.

MODEL	RO+SCMT		RO+SCMT			RO+MIN-TECH
	ProPlanet P7	ProPlanet P6	ProPlanet P4	ProPlanet P3	ProPlanet P5	ProPlanet P1
						
<b>MAIN TECHNOLOGY</b>	RO + SCMT	RO + SCMT	RO + SCMT	RO + SCMT	RO + SCMT	RO+MIN-TECH
100% RO WATER PURIFIER	✓	✓	✓	✓	✓	✓
TOTAL STAGES	8	8	8	8	8	7
<b>FILTRATION STAGES</b>						
Pre-Filter	✓	✓	✓	✓	✓	✓
Sediment Filter	✓	✓	x	x	✓	x
SCB Filter®	✓	✓	Sediment + Carbon Filter	Sediment + Carbon Filter	✓	Sediment + Carbon Filter
ART™MAX (Advance Recovery Technology™) (Patent Applied)	✓	✓	✓	✓	✓	✓
Side Stream RO Membrane	✓	✓	✓	✓	✓	✓
MIN-TECH (Mineraliser Technology)	✓	✓	Yes, Alkaline Min-Tech	Yes, Alkaline Min-Tech	✓	SCM-TECH® Filter [MIN-TECH + SAPC]
ZX Double Protection Dual Filter® (Patent Applied)	(SAPC) ✓	✓	✓	✓	✓	✓
	(SCMT) ✓	✓	✓	✓	✓	x
<b>CONVENIENCE FEATURES</b>						
Storage Capacity (Approx)	Upto 10 Ltrs (9.2 Ltrs + 0.8 Ltrs steel hot tank)	Upto 10 Ltrs (9.2 Ltrs + 0.8 Ltrs steel hot tank)	5 Ltrs	5 Ltrs	9 Ltrs	9 Ltrs
Water Dispensing Type	Touch	Faucet	Faucet	Faucet	Faucet	Faucet
Hot Water	✓	✓	x	x	x	x
Child-Lock	✓	✓	x	x	x	x
Night Assist	✓	✓	✓	✓	x	x
Auto Fill	✓	✓	✓	✓	✓	✓
Advance Alert Technology for Filters	✓	✓	✓	✓	✓	✓
Removable Drip Tray	✓	✓	x	x	✓	✓
Water Level Indicator	✓	✓	x	x	✓	✓
Mounting Options	Wall/Table	Wall/Table	Wall	Wall	Wall/Table	Wall/Table
Display	Digital	Digital	Digital	Digital	Digital	LED
<b>SPECIFICATIONS</b>						
Dimension (H x D x W) in mm	482 x 369 x 326	482 x 369 x 326	460 x 267 x 380	460 x 267 x 380	490 x 329 x 315	503 x 325 x 314
Pressure rating in psi***	7 ~ 30	7 ~ 30	7 ~ 30	7 ~ 30	7 ~ 30	7 ~ 30
Input Voltage in watt	150 ~ 300V AC / 50 Hz	150 ~ 300V AC / 50 Hz	150 ~ 300V AC / 50 Hz	150 ~ 300V AC / 50 Hz	150 ~ 300V AC / 50 Hz	150 ~ 300V AC / 50 Hz
Power rating watt (Max)	60	60	60	60	48	48
Heating Element in watt	500 @ 230VAC	500 @ 230VAC	Not applicable	Not applicable	Not applicable	Not applicable
UV LED Technology	Not applicable	Not applicable	7 mW	Not applicable	Not applicable	Not applicable
% Recovery**	>60%	>60%	>60%	>60%	>60%	>60%
TDS reduction**	≥95% (approx.)	≥95% (approx.)	≥95% (approx.)	≥95% (approx.)	≥95% (approx.)	≥95% (approx.)
Water flow rate	Upto 15 Litres/hour	Upto 15 Litres/hour	Upto 15 Litres/hour	Upto 15 Litres/hour	Upto 15 Litres/hour	Upto 15 Litres/hour
Suitable for TDS level	Upto 2000 ppm	Upto 2000 ppm	Upto 2000 ppm	Upto 2000 ppm	Upto 2000 ppm	Upto 2000 ppm
Suitable for hardness level	Upto 500 ppm	Upto 500 ppm	Upto 500 ppm	Upto 500 ppm	Upto 500 ppm	Upto 500 ppm
Storage Tank Material	Food Grade	Food Grade	Food Grade	Food Grade	Food Grade	Food Grade
<b>WARRANTY</b>						
1-Year Comprehensive Warranty	Yes* (including all filters and RO membrane)	Yes* (including all filters and RO membrane)	Yes* (including all filters and RO membrane)	Yes* (including all filters and RO membrane)	Yes* (including all filters and RO membrane)	Yes* (including all filters and RO membrane)
<small>◆Under standard test condition. For more details refer <a href="http://www.aosmithindia.com">www.aosmithindia.com</a>   *Input water should have TDS &lt;2000 ppm, in case it exceeds refer to product manual for warranty details.   **For detailed specifications please refer product manual.   ***If input pressure exceeds 30 psi, a pressure reducing valve needs to be installed at the feed line. If the pressure is lower than 7 psi, a booster pump needs to be installed.</small>			<small>For more details refer <a href="http://www.aosmithindia.com">www.aosmithindia.com</a>. Product colour and image may vary from the actual product. A. O. Smith reserves the right to amend or modify the specifications and features at any time, as and when required without any prior notification.</small>			

# We've raised the bar. For water heaters too.



In addition to water purifiers, we've also brought international-standard water heaters to India. Lined with our patented Blue Diamond® Technology, our water heaters are designed to withstand excess sedimentation and pressure fluctuations. Unlike ordinary water heaters we've engineered ours to not just match the bar set by Indian regulation authorities, but far exceed it. In addition, we've also put in place a wide network of specially trained engineers, so you get the same level of after sales service

